

Cabinet Integration

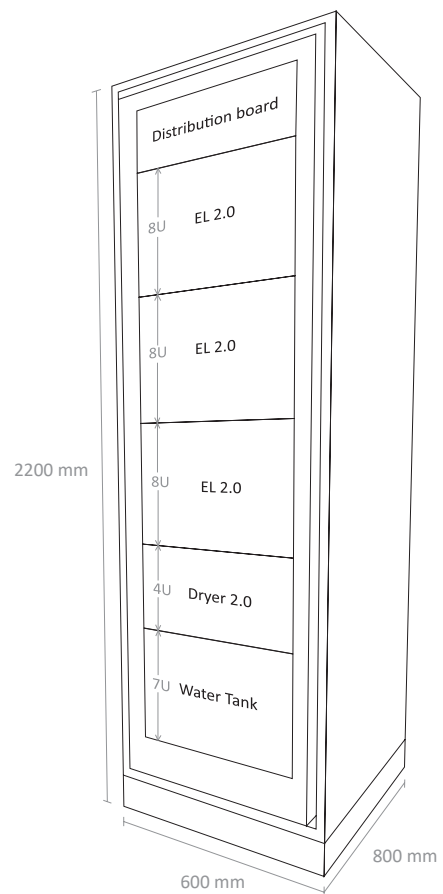

Model configuration, 3x EL 2.0, 1x Dryer 2.0, 1x Water Tank

Up to four of our stackable, modular EL 2.0 and one Dryer 2.0 can be integrated in a 19" cabinet. Several cabinets can be used to build larger systems.

Specifications

IP rating	IP20 Indoor Cabinet
Cabinet type	Rittal DK 5530.181
Measurements and weight	
Cabinet Outside Dimensions	WxDxH in mm = 600 x 800 x 2200
Available size inside	42U
Cabinet Weight	130 kg
Surrounding free space requirements	
	Front: 1.5 m - for working access and airflow Back: 0.5 m - for airflow Side, top and bottom: no minimum distance required
Cooling	Passive. Airflow for stack cooling is blown for each module individually from front to back.
Location of connections and Piping	All piping and electrical connections are located in the front of the machine. Power, water and vent lines are located at the bottom of the back of the cabinet.
Filters	No filters needed
Ambient Temperature	5-45°C
Relative humidity	20-95% non-condensing